



**OWNER'S
MANUAL
FOR AR-15
CAR-15**



OLYMPIC ARMS, INC.

624 OLD PACIFIC HIGHWAY S.E.
OLYMPIA, WA 98503
(206) 459-7940

April, 1992

WARNING

To avoid accidental firing, **BE SURE WEAPON IS CLEAR**. Failure to do so could result in serious injury or death.

Be sure the cam pin is installed in the bolt group. If it isn't, your rifle can still fire and will explode causing injury or death.

DO NOT exchange or switch bolt assemblies from one AR-15 to another. It could cause damage to both you and your rifle.

DON'T OVERHEAT YOUR AR-15 BARREL. Sustained firing of the AR-15 will rapidly raise the temperature of the barrel to a critical point.

Firing 140 rounds, rapidly and continuously, will raise the temperature of the barrel to the **COOKOFF POINT**. At this temperature, any live round remaining in the chamber for any reason may detonate (cookoff) in as short a period as 10 seconds.

If the cookoff point is felt to be possible, *clear your weapon and allow it to cool*.

Sustained rate of fire for the AR-15 is 12-15 rounds per minute. This is the actual rate of fire that this weapon can continue to deliver for an indefinite length of time without seriously overheating.

Sustained rate of fire should never be exceeded except under circumstances of extreme urgency.

If your bolt fails to unlock and you try to free it by banging the buttstock on the ground, keep clear of the muzzle.

If there's water in the barrel, don't fire the rifle. It could explode.

If you experience a noticeable difference in sound or recoil, **STOP FIRING**. Either condition could indicate an incomplete propellant burn and a bullet still in the bore. Retract bolt slowly and remove fired cartridge case. Clear weapon and check for unburned powder grains in the receiver or bore, and for a bullet in the bore. Remove unburned propellant or bullet from bore before resuming firing or barrel could explode. If bullet is lodged in bore, take your rifle to a qualified gunsmith.

If your rifle stops firing with a live round in the chamber of a hot barrel, remove the round quickly. If you cannot remove the round within 10 seconds, point the rifle in a safe direction and wait 15 minutes. In this way, you won't be injured by a possible ammunition cookoff, which could happen within 10 seconds after contact with a hot chamber. Clear rifle.

Use only authorized ammunition that is manufactured to U.S. specifications.

Please read this manual carefully before attempting to use your AR-15.

REPORTING ERRORS AND RECOMMENDING IMPROVEMENTS

You can help us improve this manual. If you find any mistakes or if you know of a way to improve the procedures, please let us know. Mail your letter to Olympic Arms, Inc., 624 Old Pacific Highway S.E., Olympia, WA 98503, and we will try to incorporate your suggestions in the next update of this manual. *Thank you.*

Table of Contents

Technical Principles of Operation, AR-15	2
Operating Instructions	
Description and Use of Operator's Controls	3
Sight Adjustments	4
Magazine Insertion and Loading	6
Chambering and Firing	7
Clearing Your AR-15	8
Operation Under Unusual Conditions	10
Field Stripping	11
Hand Guards - The "Buddy System"	11
Maintenance of Upper Receiver and Barrel Assembly	15
Maintenance of Charging Handle Assembly and Bolt Carrier Assembly	16
Maintenance of Lower Receiver and Extension Assembly	19
Reassembly of AR-15	20
Functional Check	24

Technical Principles of Operation

NOTE:

Magazine may be loaded with bolt assembly open or closed.

1. Place selector on **SAFE**
2. Insert loaded cartridge magazine in magazine well and chamber a round.
3. Face the target, move the selector lever from **SAFE** to **FIRE** and place the rifle to your shoulder.
4. Align the front and rear sight with the target and squeeze the trigger.
5. Squeezing the trigger releases the firing pin and allows it to impact the primer on the round.
6. The primer ignites the propellant in the round.
7. Gas from the burning propellant pushes the projectile along the barrel of the rifle.
8. The rifling in the barrel causes the projectile to rotate, which provides stability during flight to the target.
9. When the round reaches the approximate end of the barrel, expanding gases from burning propellant pass out through gas port and into gas tube. Gas goes into bolt carrier assembly, ejects old cartridge, and chambers a new round.

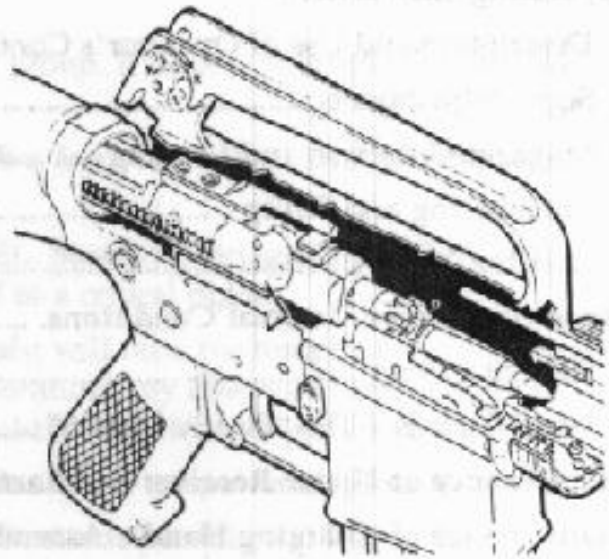

Operating Instructions

Description and Use of Operator's Controls and Indicators

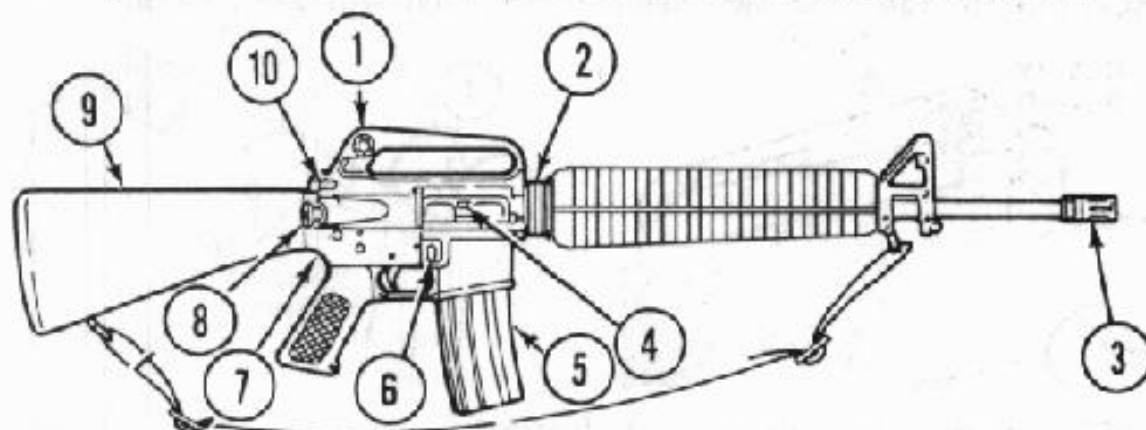

MECHANICAL CONTROLS

REAR SIGHT (1) – zeroes weapon and engages targets to 460 meters.

HAND GUARD SLIP RING (2) – keeps hand guards in place.

FLASH SUPPRESSOR (3) – reduces the amount of flash from muzzle when weapon is fired.

EJECTION PORT COVER (4) – protects upper receiver from foreign matter when weapon is not in use. Keep port cover closed when not used.

CARTRIDGE MAGAZINE (5) – supplies ammunition to weapon.

MAGAZINE CATCH BUTTON (6) – releases cartridge magazine (5) from weapon when pushed.

LOWER RECEIVER AND EXTENSION ASSEMBLY (7) – provides firing control for the weapon and provides storage for basic cleaning materials.

FORWARD ASSIST ASSEMBLY (8) – ensures that bolt is fully forward and locked.

SHOULDER GUN STOCK ASSEMBLY (9) – stabilizes rifle.

CHARGING HANDLE ASSEMBLY (10) – cocks weapon when preparing to fire or clearing weapon.

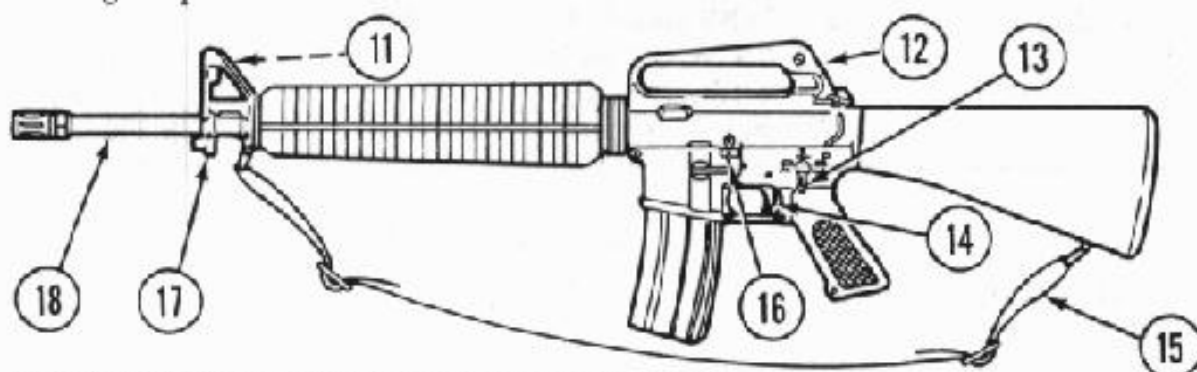

FRONT SIGHT POST (11) – adjustable for elevation.

CARRYING HANDLE ASSEMBLY (12) – provides the means for hand-carrying the rifle.

SELECTOR LEVER (13) – arms the rifle in fire or safes the rifle.

TRIGGER (14) – controls the firing of the weapon.

SMALL ARMS SLING (15) – provides the means for shoulder-carrying the weapon.

BOLT CATCH (16) – moves the key and bolt carrier assembly forward when depressed.

UPPER RECEIVER AND BARREL ASSEMBLY (17) – directs the projectile upon firing.

Sight Adjustments - A-1 Type

RIFLE SIGHTS (ZERO ADJUSTMENT) - Move front (1) and rear (2) sights to make sure they can be adjusted. Return sights to zero setting of your rifle.

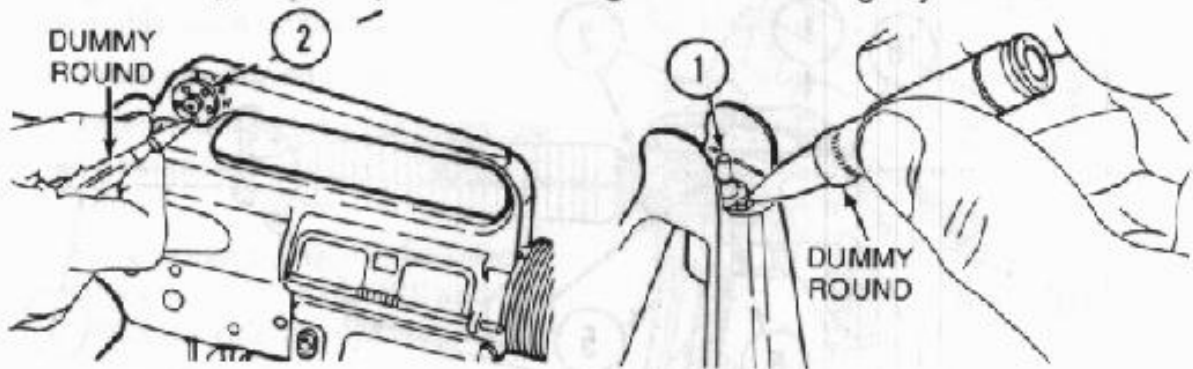

REAR SIGHT - To adjust windage, depress detent and rotate drum to direction you want:

1. To move point of impact to right, turn drum clockwise in direction of arrow and letter R.
2. To move left, move drum counterclockwise.
3. Each notch moves the point of impact of bullet as indicated in chart.

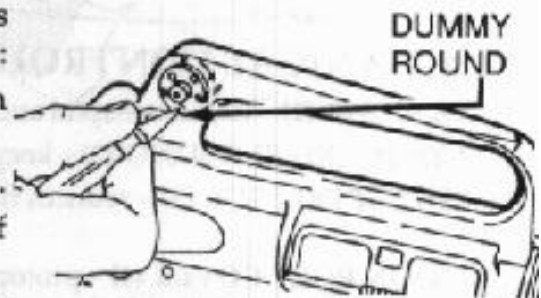

FRONT SIGHT - To adjust elevation, depress detent and rotate post:

1. To raise strike of bullet, rotate post in the direction of arrow marked up.
2. Reverse the direction of rotation to lower strike of bullet.
3. Each notch moves the point of impact of bullet as indicated in chart.

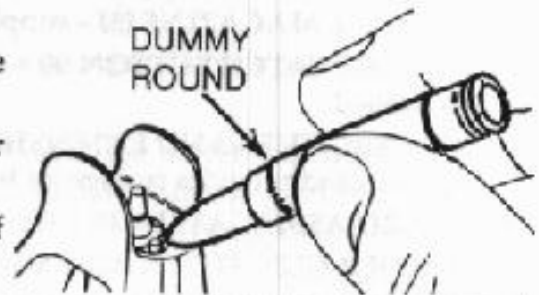

IMPACT (1 CLICK)		DISTANCE
STANDARD SYSTEM	LOW LIGHT LEVEL SIGHT SYSTEM	AT
0.7 cm (17/64 in.)	0.9 cm (23/64 in.)	25 meters
2.8 cm (1-3/32 in.)	3.5 cm (1-3/4 in.)	100 meters
5.6 cm (2-13/64 in.)	7.0 cm (2-3/4 in.)	200 meters

Sight Adjustments - E-2 Type

ADJUSTABLE FRONT SIGHT POST

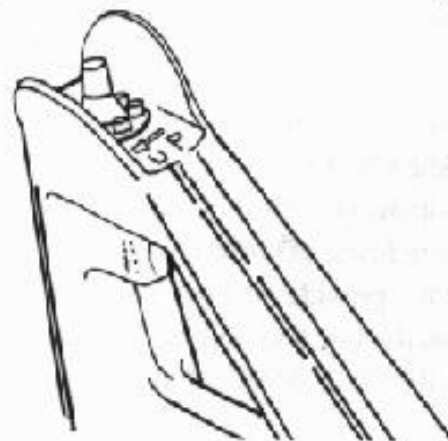

1. The front sight post is moved up or down when zeroing the rear sight. Once the rear sight is zeroed, the front sight post should not be moved.

Sight Adjustments – E-2 Type (cont'd)

ADJUSTABLE REAR SIGHT HAS TWO APERTURES FOR RANGE

SHORT RANGE (0-200 METERS)

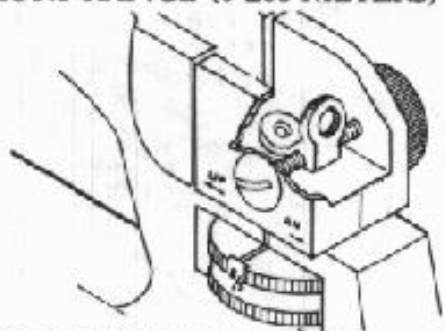

2. **SHORT RANGE** – The “larger” aperture is used for 0-200 meters range. As shown, the sight is set for 0-200 meters. This larger aperture is only used when the rear sight is all the way down – the 300-meter mark is aligned with the mark on the left side of the receiver.

BATTLESIGHT ZERO

When battlesights are on your rifle:

1. The front sight post and rear sight windage knob are adjusted so you can hit your point of aim at 300 meters.
2. The unmarked aperture must be in the up position.
3. The 300-meter mark is aligned with the mark on the left side of the receiver.

NORMAL RANGE (300-800 METERS)

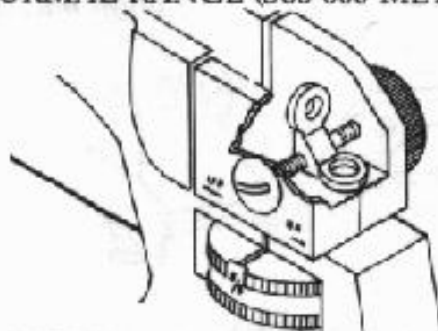

3. **NORMAL RANGE** – The aperture is unmarked and used for most firing situations. It is used in conjunction with the elevation knob for 300, 400, 500, 600, 700 and 800 meter targets.

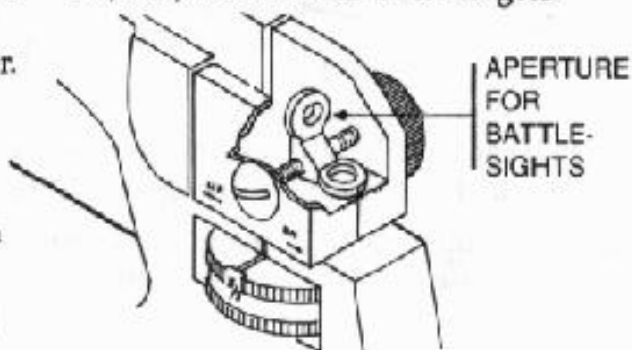

300 METERS ON ELEVATION KNOB (DIAL ROTATED ALL THE WAY DOWN)

BATTLESIGHT ZEROING ADJUSTMENTS

1. During zeroing procedures, *only the front sight post and windage knob* are adjusted to move the strike of the bullet on the target.
2. If you are zeroing on a 25-meter range, the rear sight elevation knob is adjusted to the 300-meter mark plus one “click” up.

BATTLESIGHT ZEROING ADJUSTMENTS (all values rounded off)

FOR WINDAGE KNOB (per click)

IMPACT	DISTANCE
0.3 cm (.175")	25 meters
1.25 cm (.5")	100 meters
2.5 cm (1")	200 meters
3.8 cm (1.5")	300 meters
5.0 cm (2")	400 meters
6.3 cm (2.5")	500 meters
7.6 cm (3")	600 meters
8.8 cm (3.5")	700 meters
10.0 cm (4")	800 meters

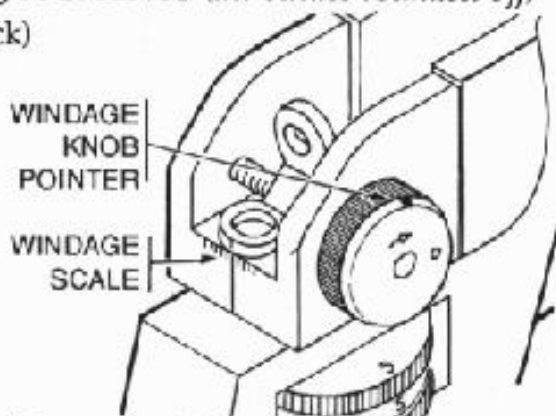

To remember your correct battlesight zero windage, note location of windage scale and windage knob pointer (heavy mark on outside of knob).

Keep your correct battlesight zero windage on the rifle at all times.

Loading WARNING

Point muzzle in a safe direction

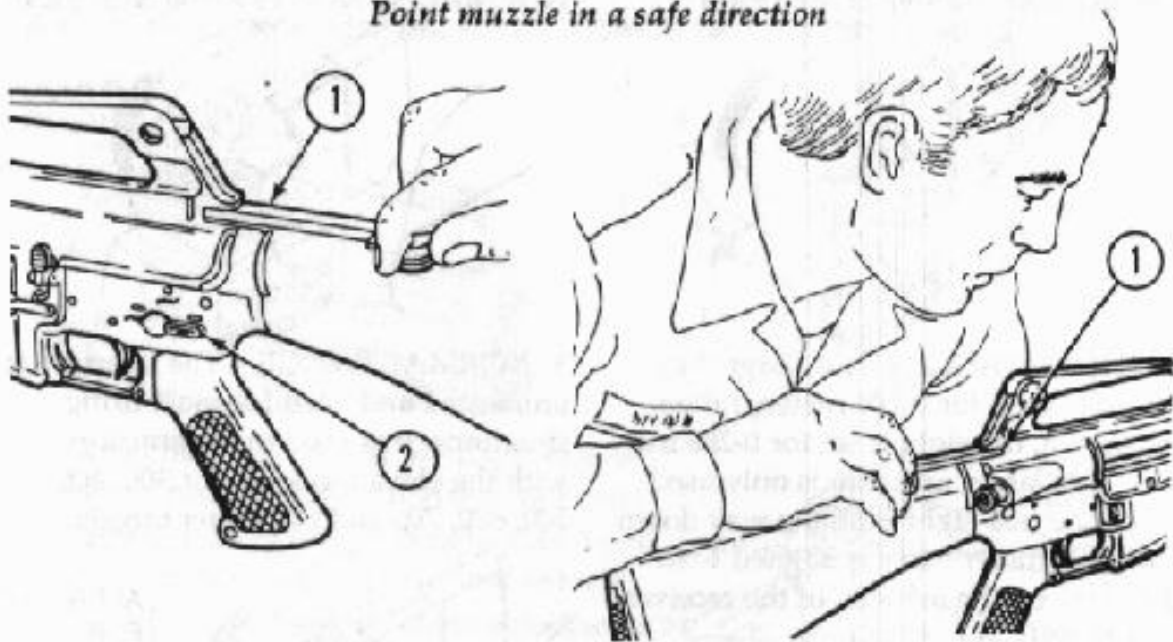

1. Pull charging handle assembly (1) rearward, lock bolt, and release charging handle. Place selector lever (2) on SAFE.
2. Pull charging handle assembly (1) rearward and check to see that chamber is clear. Release charging handle assembly.

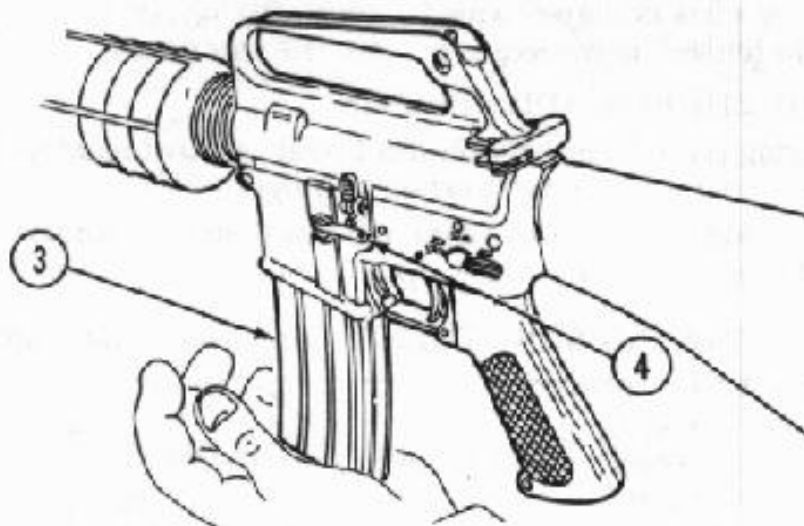

NOTE

Magazine may be loaded with bolt assembly open or closed.

Push upward on cartridge magazine (3) until magazine catch (4) engages and holds cartridge magazine.

Tap upward to make sure cartridge magazine is seated correctly.

Operating Procedure – Chambering and Firing a Round

BOLT ASSEMBLY OPEN

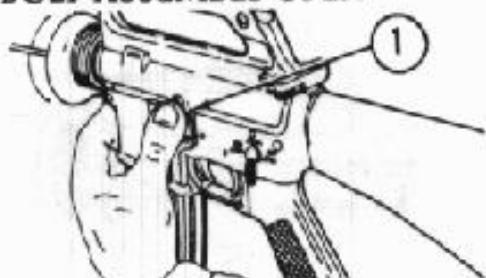

1. Depress upper portion of bolt catch (1) to release the bolt

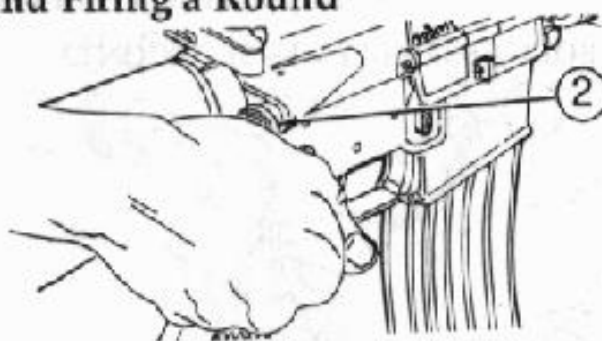

2. Tap forward assist assembly (2) to ensure bolt is fully forward and locked.

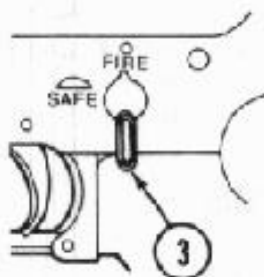

3. Move selector lever (3) to FIRE.

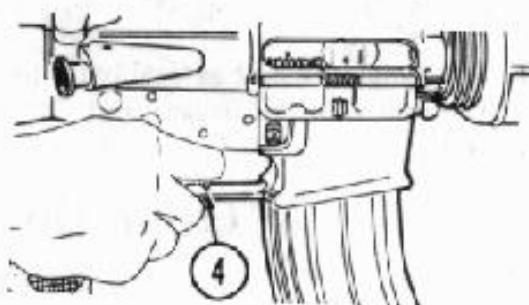

4. Squeeze the trigger (4) and fire.

BOLT ASSEMBLY CLOSED

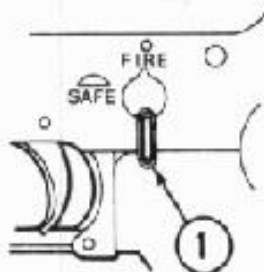

1. Place the selector lever (1) on FIRE



2. Pull charging handle assembly (2) all the way back.

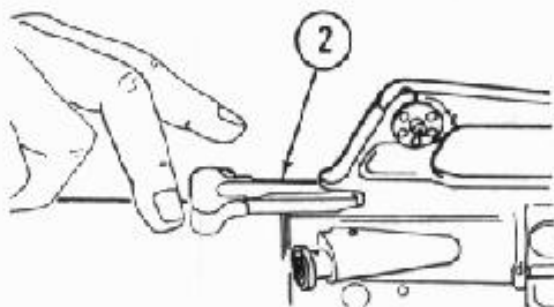

3. Release the charging handle assembly (2).

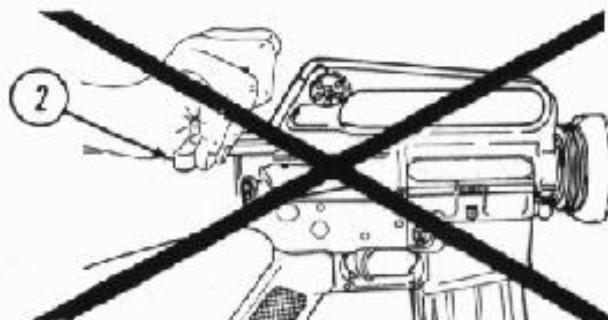

4. Never "ride" the charging handle assembly (2). Let it go on its own.

Operating Procedure – Chambering and Firing a Round (Cont.)

BOLT ASSEMBLY CLOSED (CONT.)

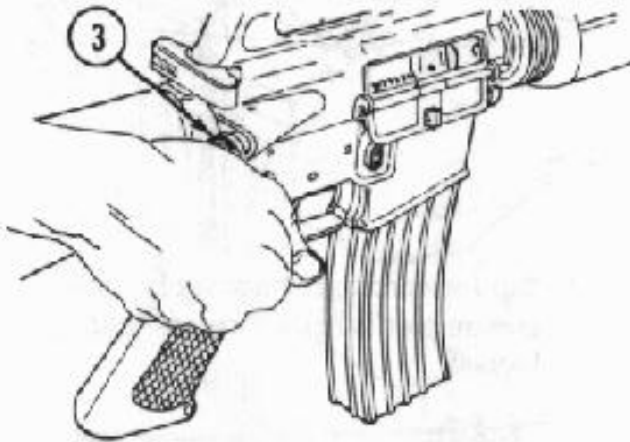

5. Tap forward assist assembly (3) to ensure bolt is fully forward and locked.



6. Squeeze the trigger (4) and fire.

Operating Procedures – Clearing Your Rifle

WARNING

To avoid accidental firing, always look into chamber after clearing weapon to make sure it does not contain a round.

1. Place selector lever (1) on SAFE.

NOTE

If weapon is not cocked, lever cannot be pointed toward SAFE.

2. Remove cartridge magazine (2) by depressing magazine catch button (3) and pulling cartridge magazine (2) down.

3 To lock bolt open, pull charging handle assembly (4) rearward, press bottom of bolt catch (5), and allow bolt to move forward until it engages bolt catch. Return charging handle assembly (4) forward.

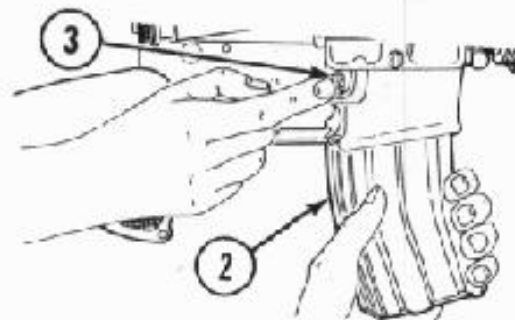
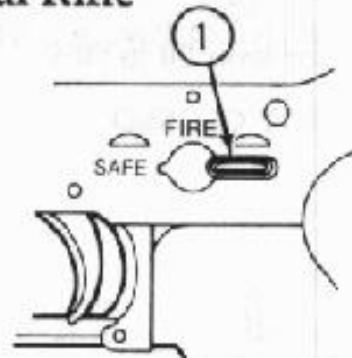

Operating Procedures – Clearing Your Rifle (Cont.)

NOTE

Ensure that selector lever (1) is on **SAFE**.

4. Check receiver and chamber (6) to ensure these areas contain no ammunition.

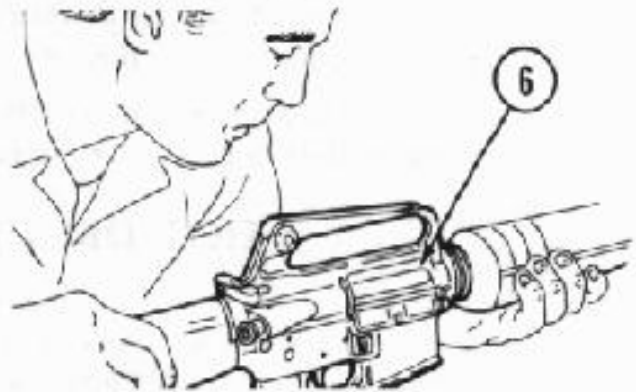

5. With selector lever (1) pointing toward **SAFE**, allow bolt to go forward by pressing upper portion of bolt catch (5).



NOTE

If weapon is to be stored, it should be dry fired to release tension on hammer spring.

6. Place selector lever (1) on **FIRE** and squeeze trigger to release tension on hammer spring.

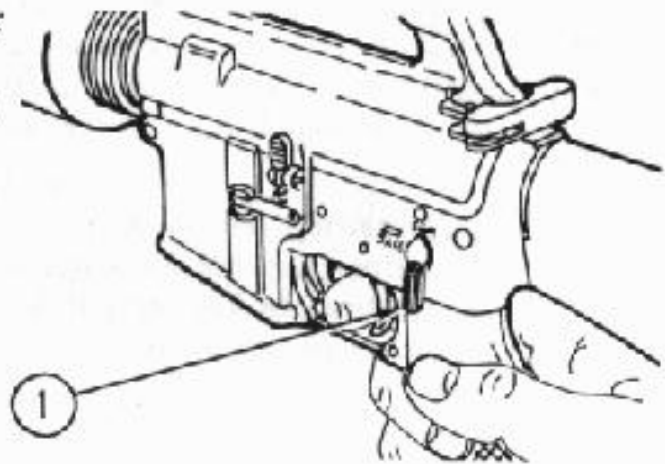

Operation Under Unusual Conditions

NOTE

Unusual conditions are defined as any climatic condition requiring special maintenance of the weapon.

Perform the maintenance outlined for the climate that most applies to your operational area.

HOT, DRY CLIMATES

NOTE

Hot, dry climates are usually dusty and sandy areas. They are hot during daylight hours and cool during the night hours.

- A. Dust and sand will get into the rifle and will cause malfunctions and excessive wear on component working surfaces through abrasive action during the firing operations.
- B. Corrosion is less likely to form on metal parts in a dry climate; therefore, lubricate internal working surfaces only with a small of cleaner, lubricant and preservative (always shake CLP prior to use). Do not lubricate external parts of the rifle. Doing so will only collect dust and sand, making the rifle difficult to keep clean. Do not lubricate internal components of the magazines.
- C. Using additional equipment – i.e., protective cap and spare magazine protective bags and overall rifle protective cover will help keep dust and sand from getting into the rifle. Use these items as the situation warrants. As a minimum effort to keep dust and sand out of your rifle, keep the ejection port cover closed, a cartridge magazine installed in the rifle, and a muzzle cap on the muzzle.

NOTE

Before firing, remove the protective cap and keep for later use. However, it is not dangerous to fire the rifle with the protective cap. The cap will blow off when the first round is fired and may be lost.

HEAVY RAIN

Perform maintenance according to the appropriate climatic condition. Use additional equipment – protective cap and spare magazine, protective bags and overall rifle protective cover as the situation warrants. Always keep the rifle dry. Using the protective cap will help keep water out of the barrel. Always drain any water from the barrel before firing. Dry the bore with a swab and cleaning rod, if necessary.

Maintenance Procedures

Field-stripping Your AR-15

CLEARING RIFLE

WARNING

To avoid accidental firing, be sure rifle is clear. Pull back charging handle (1) and check chamber (2). Place selector lever on SAFE.

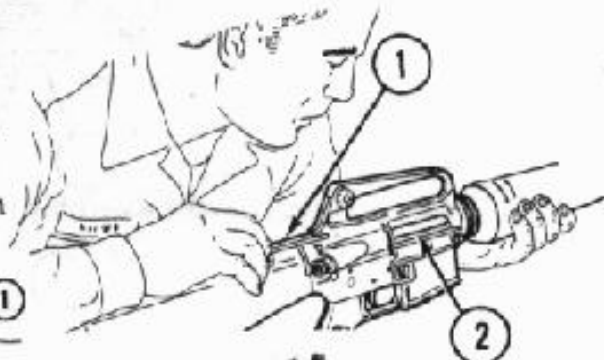

SLING

Remove sling (1)

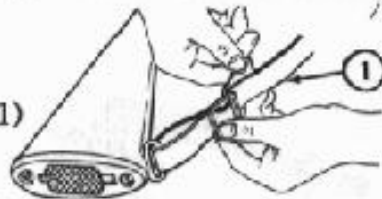

HAND GUARDS - THE "BUDDY SYSTEM"

1. Remove and clean hand guards only if dirt and corrosion can be seen through hand guard vent holes.
2. Place the weapon on the buttstock (1) with one hand gripping the stock and the other gripping the lower end of the hand guard (2).
3. While your buddy presses down on the slip ring (3) (tell him to use two hands - it's easier), pull the hand guard (2) free.
4. Repeat procedure to remove other hand guard.

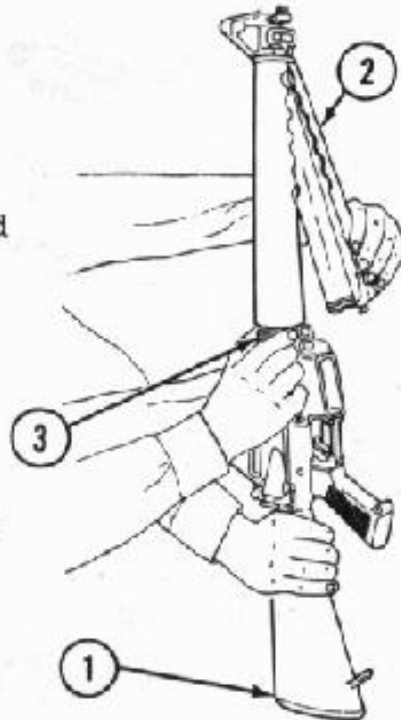

UPPER AND LOWER RECEIVERS

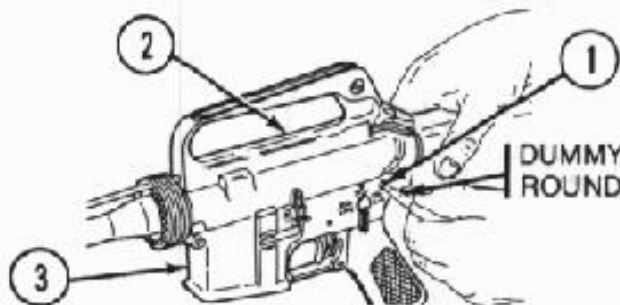

1. Push takedown pin (1) as far as it goes.



2. Pivot upper receiver (2) from lower receiver (3)

3. Push receiver pivot pin (4).

4. Separate upper (2) and lower (3) receivers.

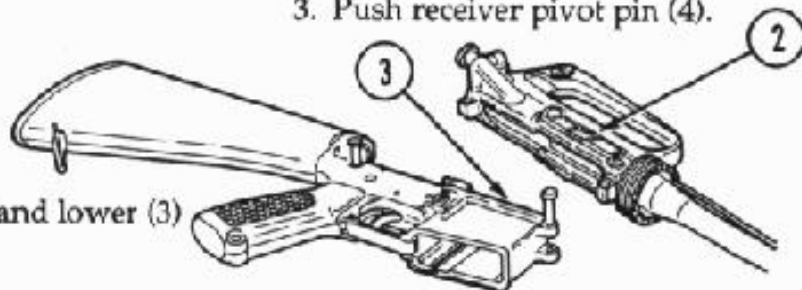

CHARGING HANDLE ASSEMBLY AND BOLT CARRIER ASSEMBLY

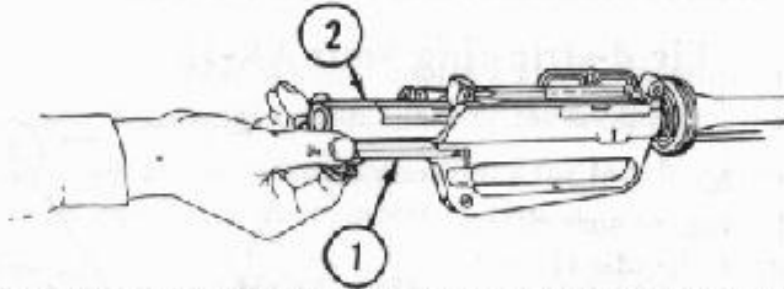

1. Pull back charging handle assembly (1) and bolt carrier assembly (2).

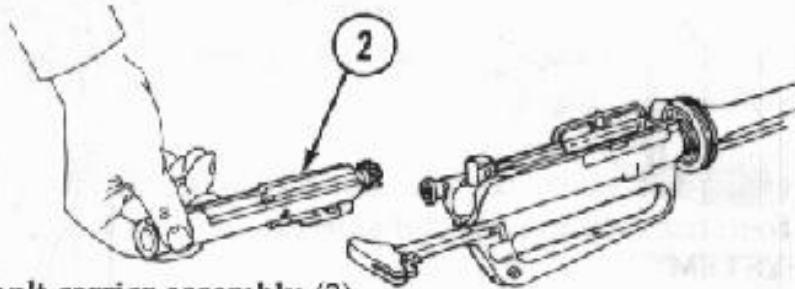

2. Remove bolt carrier assembly (2).

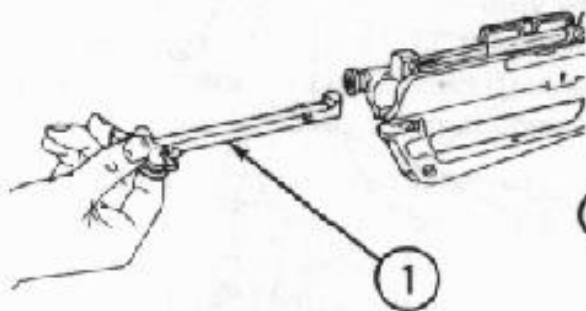

3. Pull charging handle assembly (1) back and down and remove it.

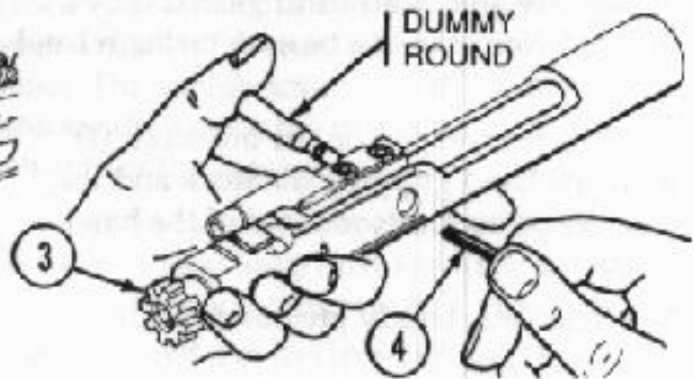

4. Move bolt assembly (3) forward to unlocked position and remove firing pin retaining pin (4). Do not open or close split end of firing pin retaining pin (4).

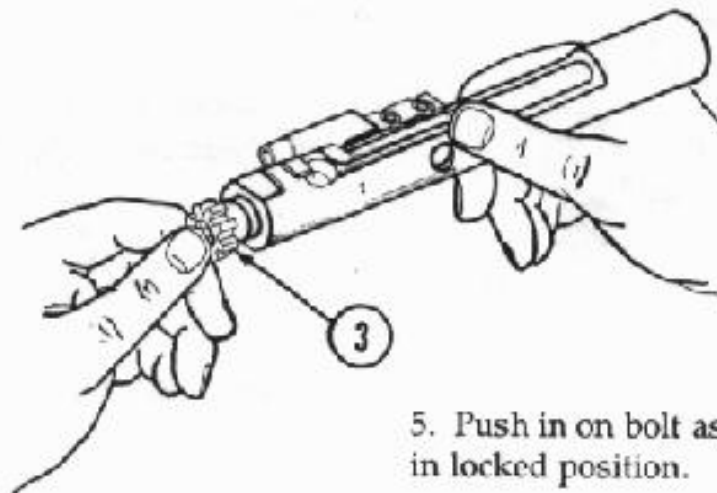

5. Push in on bolt assembly (3) to put in locked position.

CHARGING HANDLE ASSEMBLY AND BOLT CARRIER ASSEMBLY (Cont.)

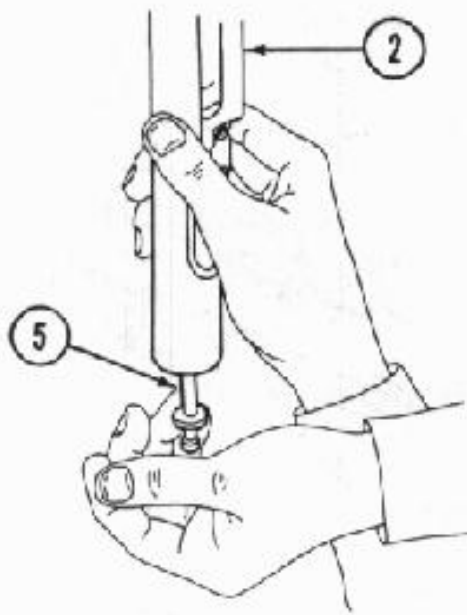

6. Catch firing pin (5) as it drops out of rear of bolt carrier assembly (2).

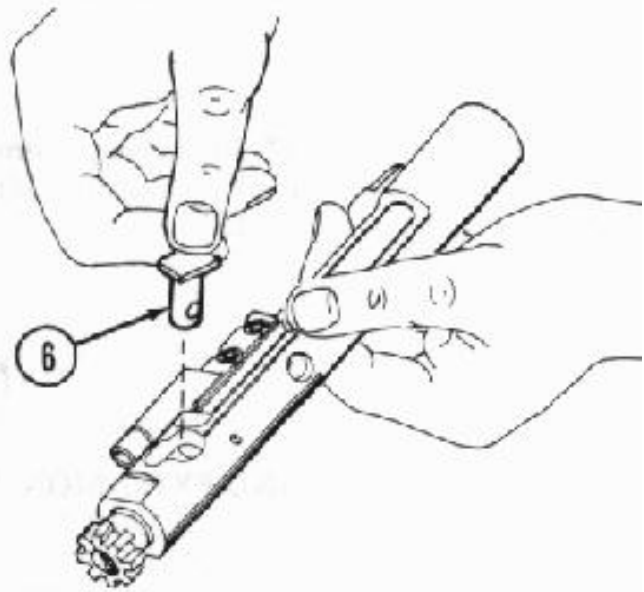

7. Give bolt cam pin (6) a 1/4 turn and lift out.

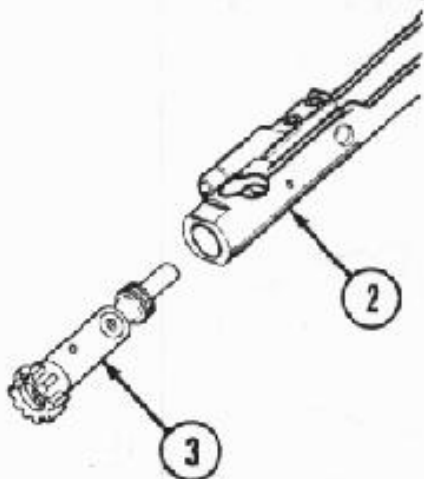

8. Remove bolt assembly (3) from bolt carrier assembly (2).

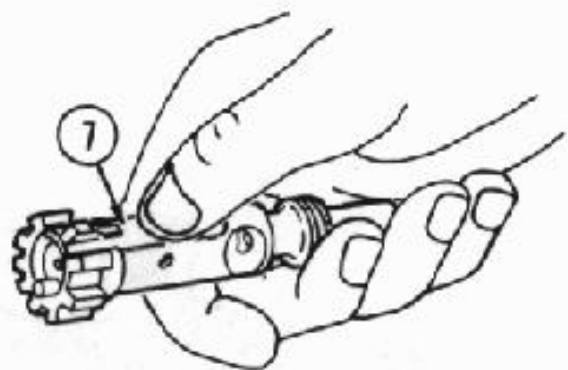

9. Press top of extractor (7) to check that spring works.

NOTE

Disassemble extractor and spring assembly only when dirty or damaged.

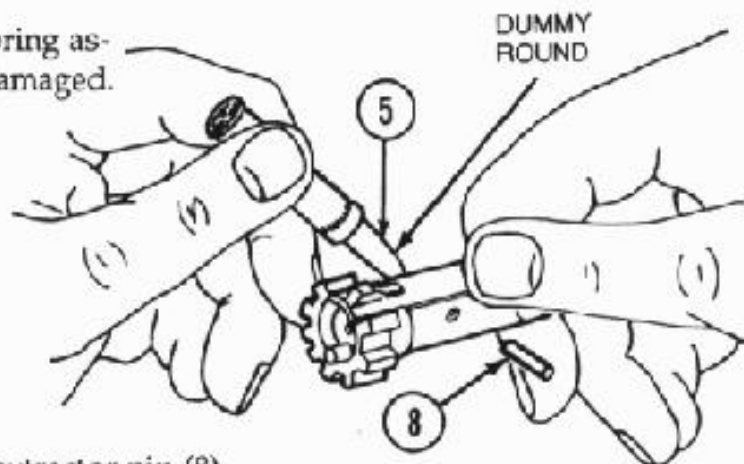

10. Use round (5) to remove extractor pin (8).

CHARGING HANDLE ASSEMBLY AND BOLT CARRIER ASSEMBLY (Cont.)

CAUTION

Do not separate insert from spring assembly (9).

11. Remove extractor (7) and spring assembly (9). Do not remove spring assembly (9) from extractor (7).

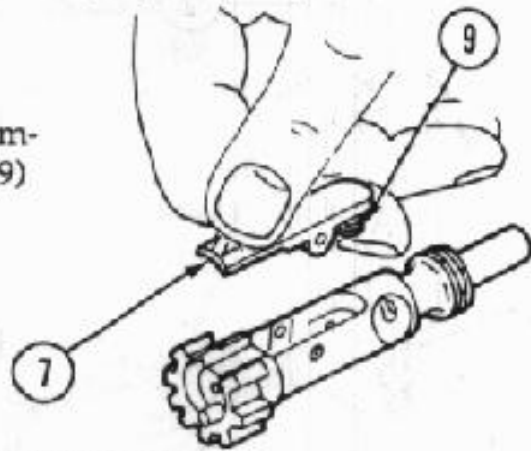

LOWER RECEIVER AND EXTENSION ASSEMBLY

1. Press in buffer (1) and depress retainer (2) to release buffer.

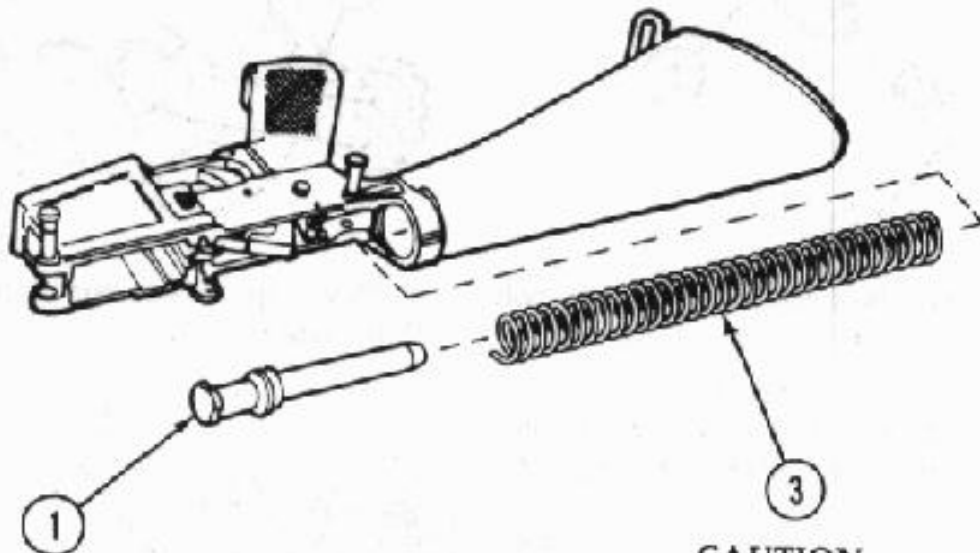
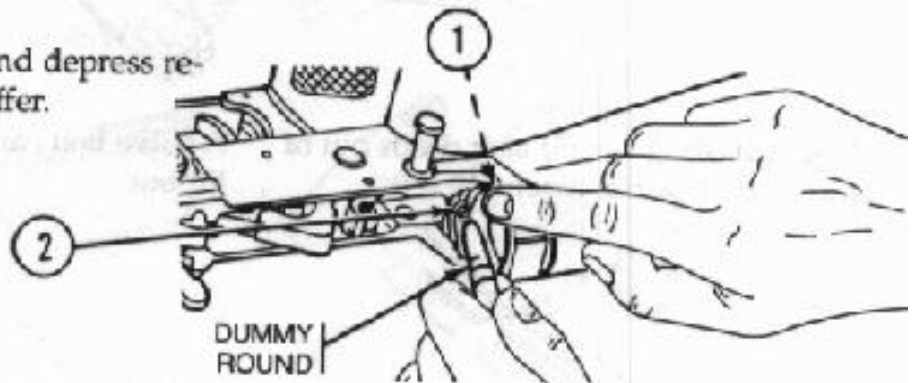

2. Remove buffer (1) and spring (3).

CAUTION

No further disassembly is advisable.

Maintenance Procedures

Maintenance of Upper Receiver and Barrel Assembly

CLEANING

NOTE

Don't reverse direction of bore brush while it is in the bore.

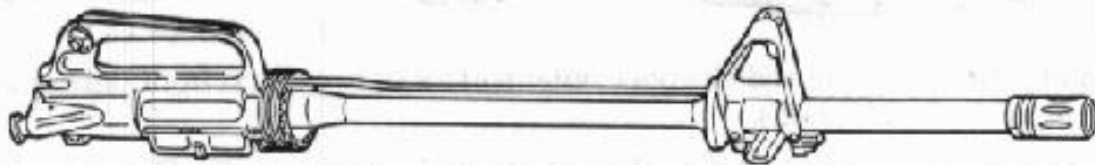

Use cleaner, lubricant and preservative (CLP) on the following areas:

- A. All areas of powder fouling, corrosion, dirt and rust.
- B. Bore and chamber.
- C. Upper receiver and barrel assembly locking lugs.
- D. Gas tube.

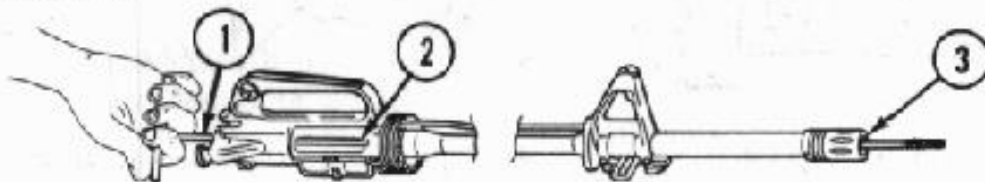

1. Use cleaning rod, bore brush, and CLP. Run rod through chamber (2) and flash suppressor (3).

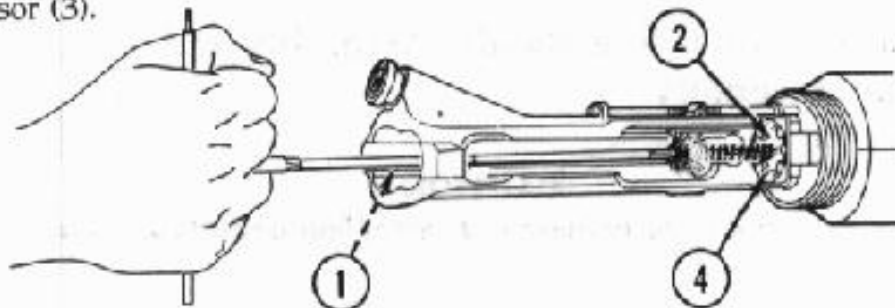

2. Install chamber brush on cleaning rod (1), dip in CLP, and insert in chamber (2) and locking lugs (4). Clean by pushing and twisting cleaning rod.

INSPECTION

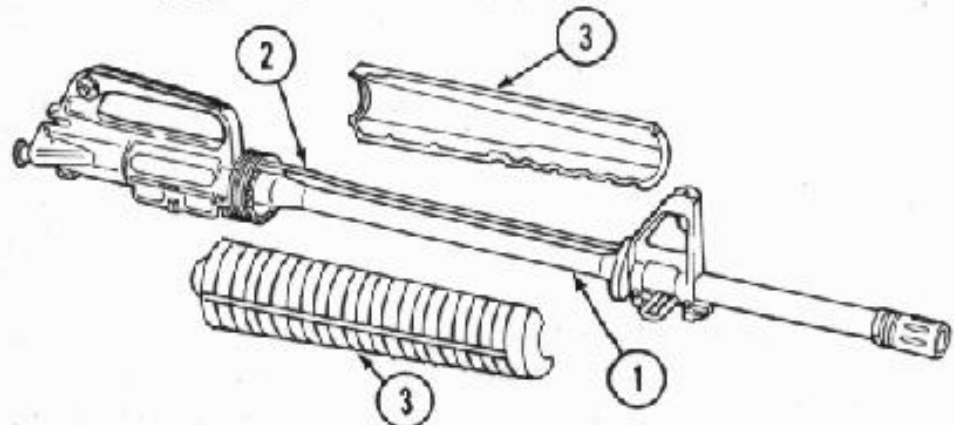

Inspect barrel (1), gas tube (2), and hand guards (3) for cracks, bends, or breaks. If you think a part is bad, check with a reputable gunsmith.

Maintenance of Upper Receiver and Barrel Assembly (Cont.)

LUBRICATION

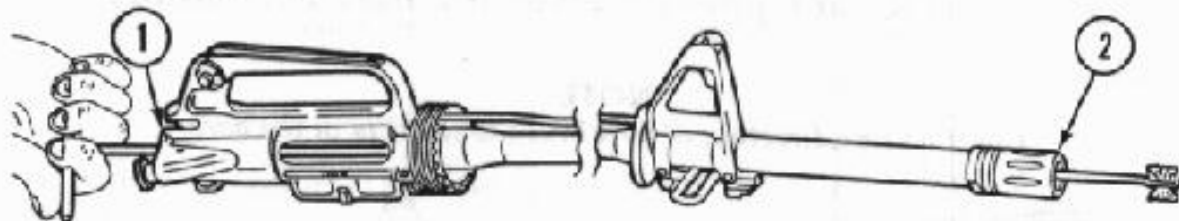

1. Lightly lubricate bore and chamber, outer surface of barrel and front sight, and surfaces under hand guards.
2. Start at receiver (1) and go right through the flash suppressor (2). Don't reverse directions in bore.

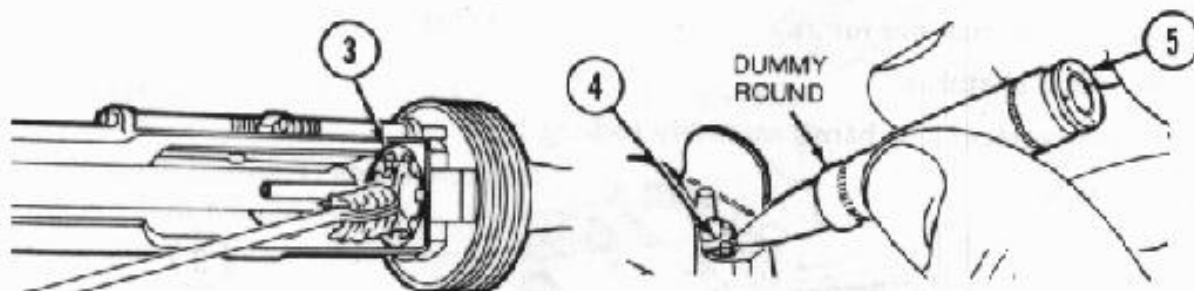

3. Lubricate locking lugs (3).
4. Depress front sight detent (4) several times to work CLP into the spring using a round (5).

Maintenance of Charging Handle Assembly and Bolt Carrier Assembly

CLEANING

CAUTION

Do not use firing pin to clean inner surfaces of bolt or bolt carrier assembly.

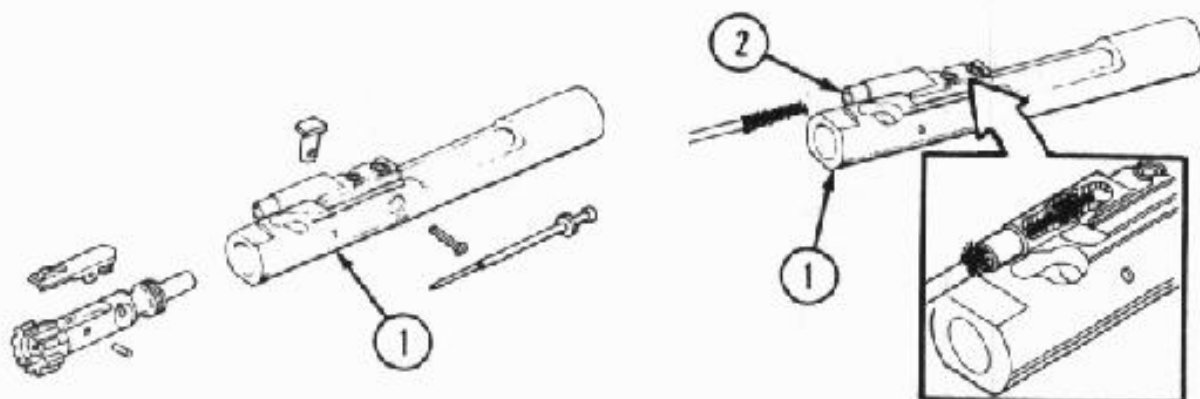

1. Clean all parts and outer surfaces of the bolt carrier assembly (1) with a swab saturated with CLP.
2. Clean the bolt carrier key (2) with a worn bore brush dipped in CLP. Dry with a pipe cleaner. Use a pipe cleaner to apply a light coating of CLP to carrier key (2).

MAINTENANCE OF CHARGING HANDLE ASSEMBLY AND BOLT CARRIER ASSEMBLY (Cont.)

3. Remove carbon deposits and dirt from locking lugs (3) with bore brush dipped in CLP.

4. Clean areas behind bolt rings (4) and under lip of extractor (5).

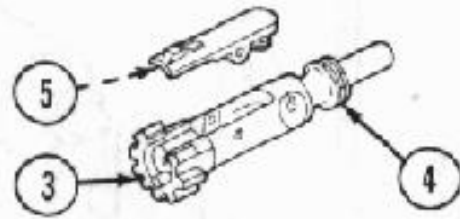

INSPECTION

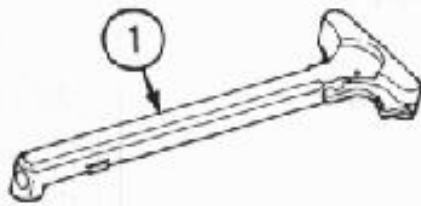

1. Inspect charging handle assembly (1) for cracks, bends, or breaks.



WARNING

DO NOT interchange bolt assemblies between rifles.

2. Inspect bolt assembly (2) for cracks and fractures, especially in the cam pin hole area.

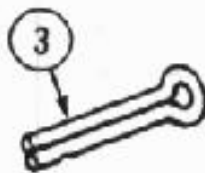

3. Inspect firing pin retaining pin (3) for bends, breaks, or dents.

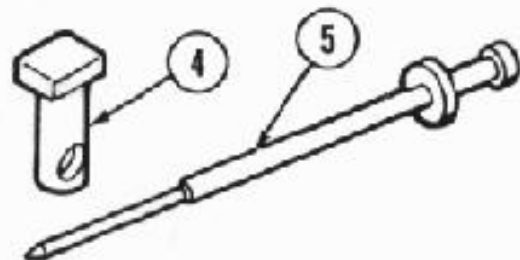

4. Inspect bolt cam pin (4) for cracks or chips.

5. Inspect firing pin (5) for bends, cracks, or blunted tip.

LUBRICATION

1. Lightly lubricate firing pin (1) and firing pin recess (2) in bolt assembly.

2. Generously lubricate outside of bolt cam pin (3) and firing pin retaining pin (4) with CLP. Make certain to lubricate bolt assembly cam pin hole (5), bolt rings (6), and outside of the bolt assembly (7).

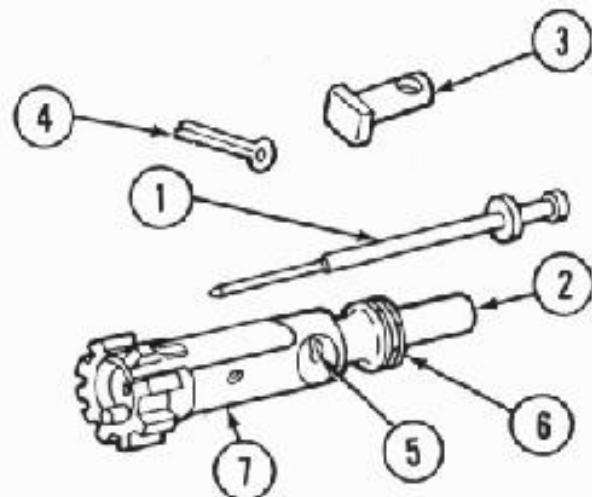

LUBRICATION (Cont.)

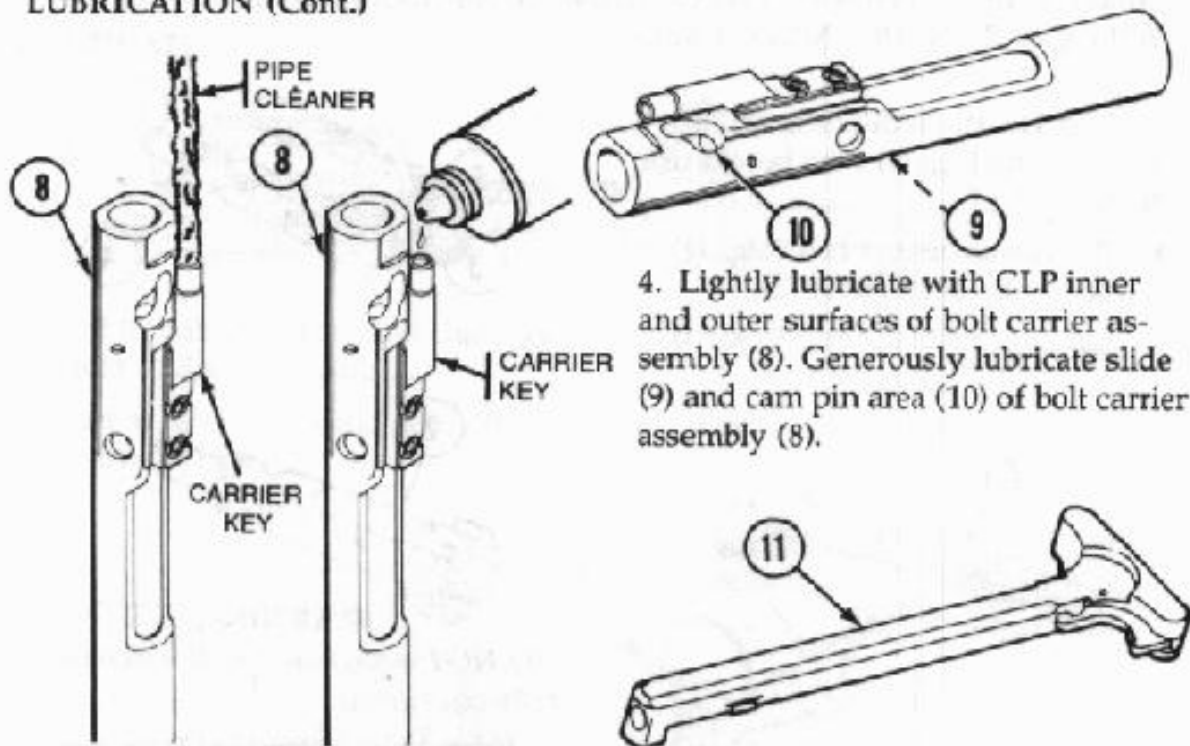

3. Dry inside key of bolt carrier assembly (8). Place one drop of CLP inside key.

4. Lightly lubricate with CLP inner and outer surfaces of bolt carrier assembly (8). Generously lubricate slide (9) and cam pin area (10) of bolt carrier assembly (8).

5. Lightly lubricate charging handle assembly (11).

CLEANING

CAUTION

Do not use steel/wire brush or any type of abrasive material to clean aluminum surfaces.

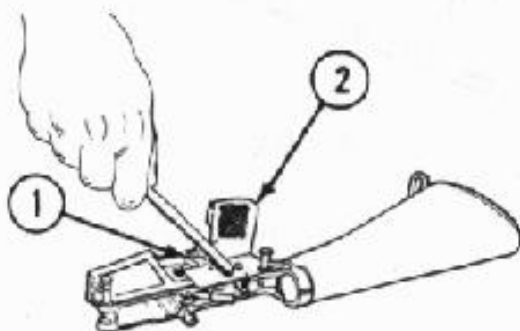

1. Wipe dirt from trigger (1) with a swab.

2. Use a swab dipped in CLP and cleaning brush to clean powder fouling, corrosion, and dirt from outside parts of lower receiver and extension assembly (2).



3. Use pipe cleaner to clean buttstock screw drain hole.

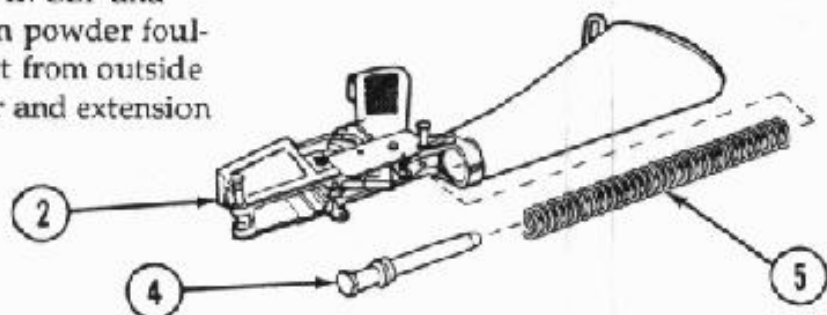

4. Clean buffer assembly (4), spring (5), and inside lower receiver and extension assembly (2) with swab dipped in CLP. Wipe dry.

Maintenance of Lower Receiver and Extension Assembly

INSPECTION

1. Examine lower receiver and extension assembly (1) for broken or bent trigger (2), buttstock (3), corroded or deformed lower receiver (1), cracked or damaged rifle grip (4), and bent or damaged selector lever (5). Look at inside parts of lower receiver and extension assembly (1) for cracks, dents, or breaks.

2. If you think the parts are bad, see a reputable gunsmith.

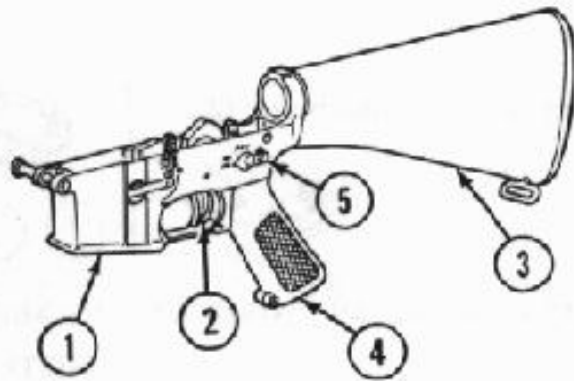

LUBRICATION

1. Lightly lubricate inside of lower receiver and extension assembly (1), spring (2), and buffer assembly (3) with CLP.

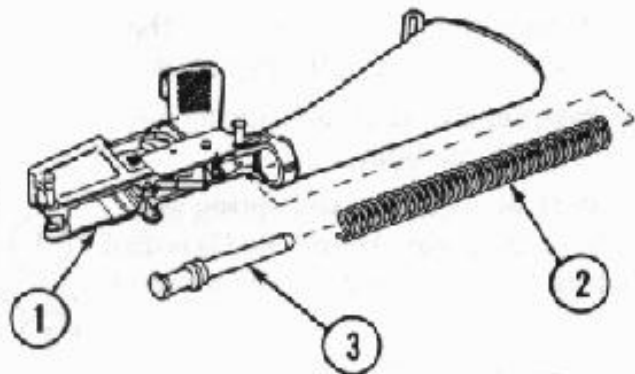

2. Generously lubricate takedown (4) and pivot pins (5) and inside parts of lower receiver and extension assembly (1) with CLP.

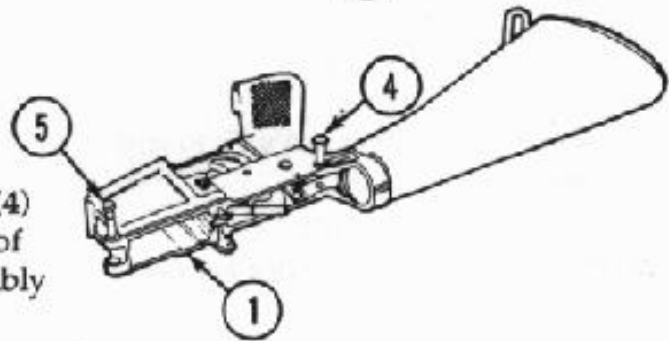

CAR-15 STOCK

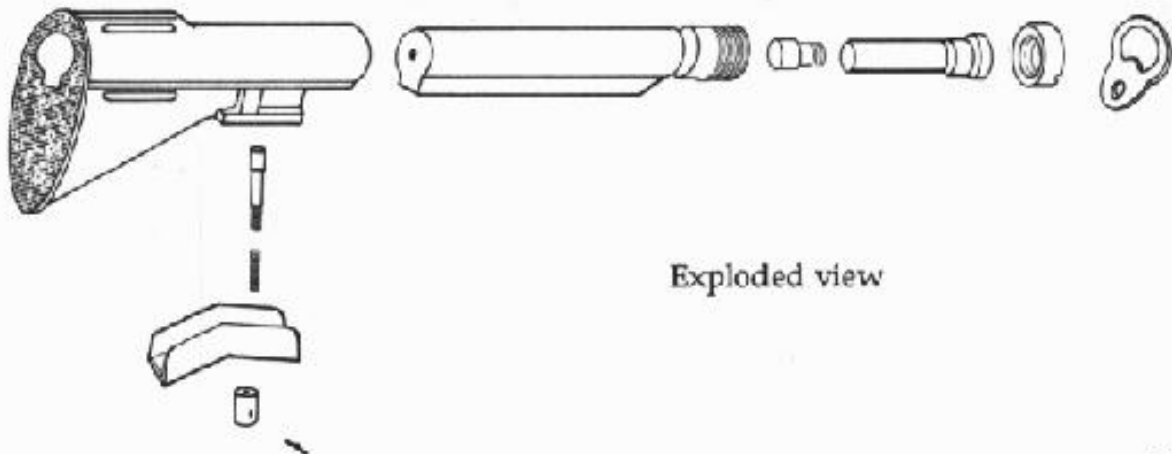

Exploded view

Reassembly of AR-15 Rifle

LOWER RECEIVER AND EXTENSION ASSEMBLY

Insert spring (1) and buffer (2).

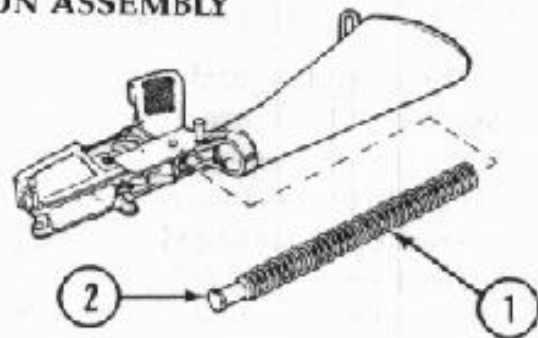

BOLT CARRIER ASSEMBLY AND CHARGING HANDLE ASSEMBLY

NOTE

*New extractor has silicone insert with spring.
Be sure not to lose it.*

1. If the spring comes loose, seat the large end of spring in the extractor.
2. Insert extractor (1) and spring assembly (2) into bolt.
3. Push extractor (1) and spring assembly (2) down. Align hole (3) with hole in bolt and insert extractor pin (4).

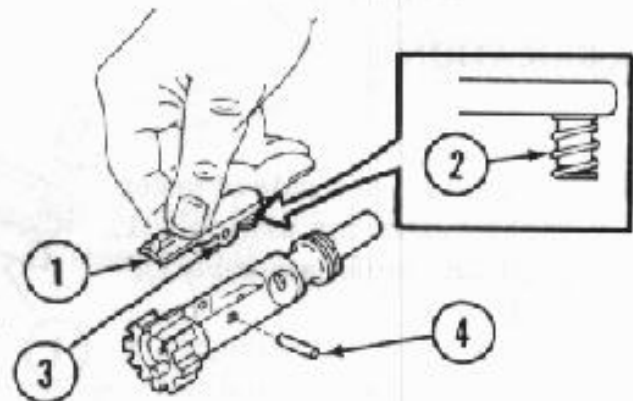

4. Stagger gaps in bolt rings (5) to stop gas loss.

WARNING

Don't switch bolt assemblies between rifles.

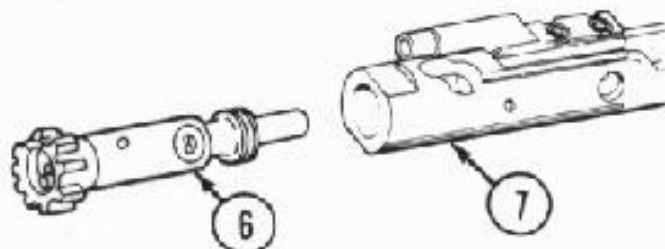

5. Slide bolt assembly (6) into bolt carrier assembly (7).

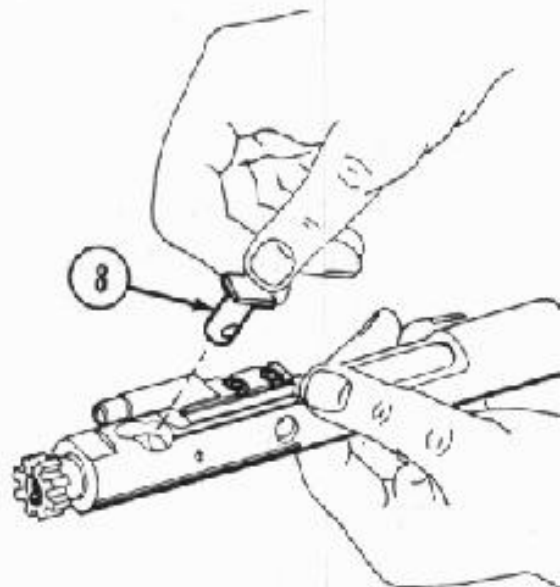

6. Insert bolt cam pin (8) and give it a 1/4 turn.

REASSEMBLY (Cont.)

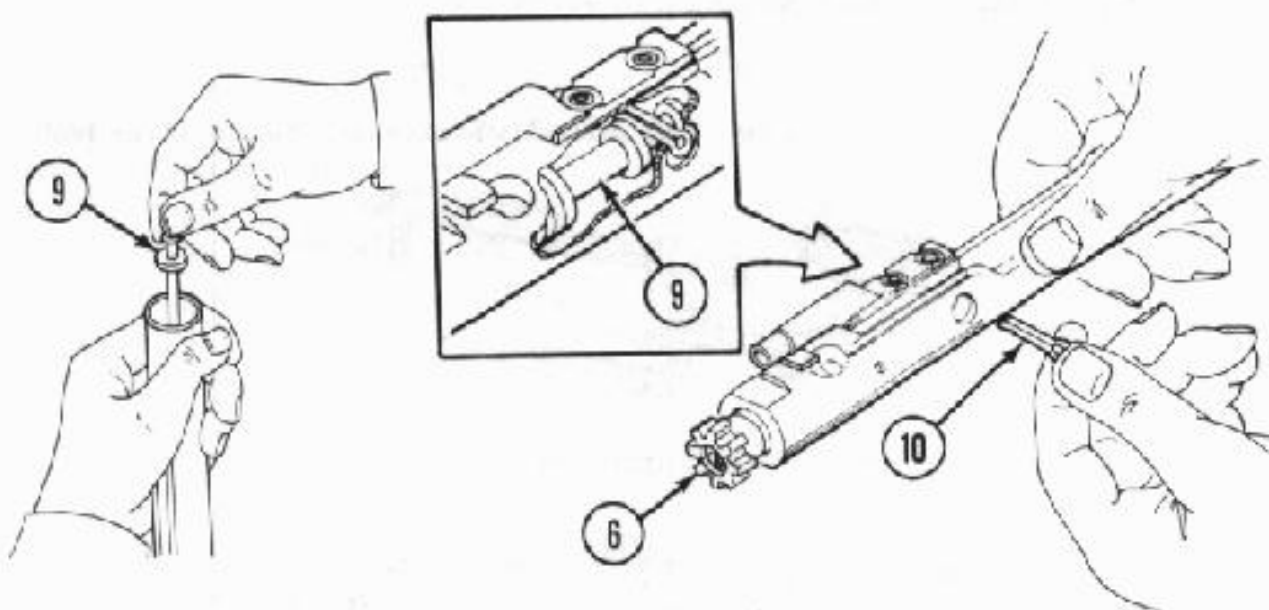

7. Drop firing pin (9) in opening and seat.

8. Pull bolt assembly (6) back and replace firing pin retaining pin (10)

NOTE

Firing pin should not fall out when bolt carrier assembly is turned upside down.

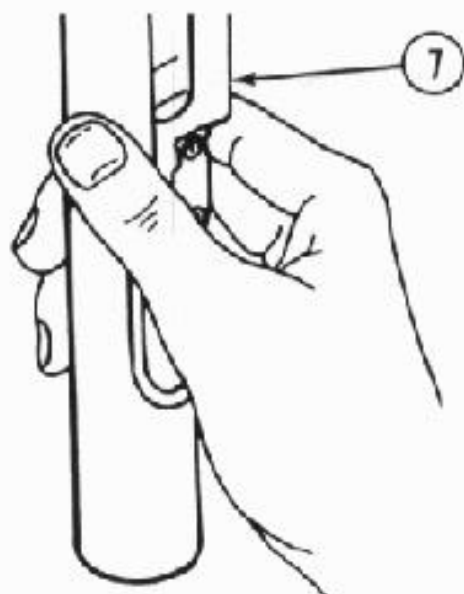

9. Turn bolt carrier assembly (7) over and try to shake out firing pin.

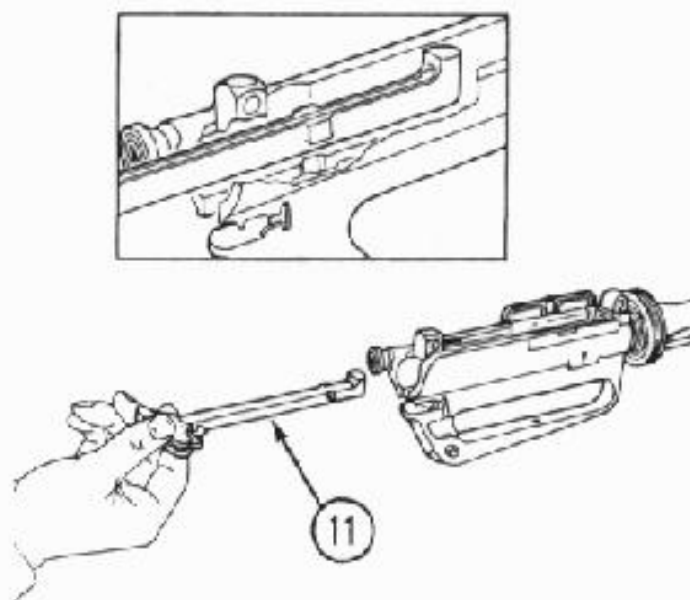

10. Engage, then push, charging handle assembly (11) part way into upper receiver.

REASSEMBLY (Cont.)

Bolt Carrier Assembly and Charging Handle Assembly

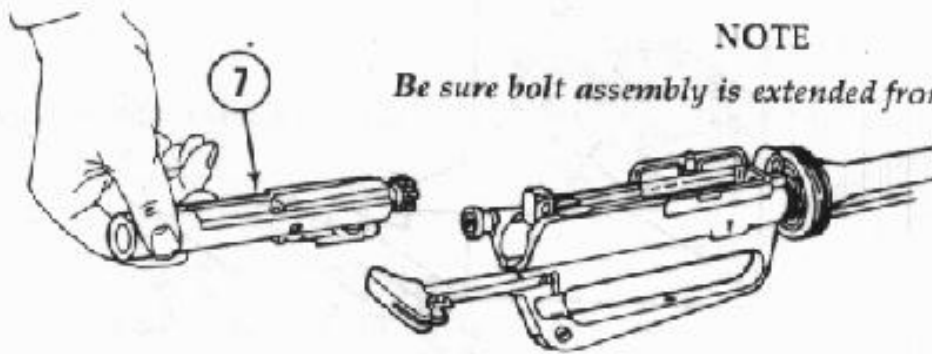

NOTE

Be sure bolt assembly is extended from bolt carrier.

11. Slide bolt carrier assembly (7) into upper receiver.

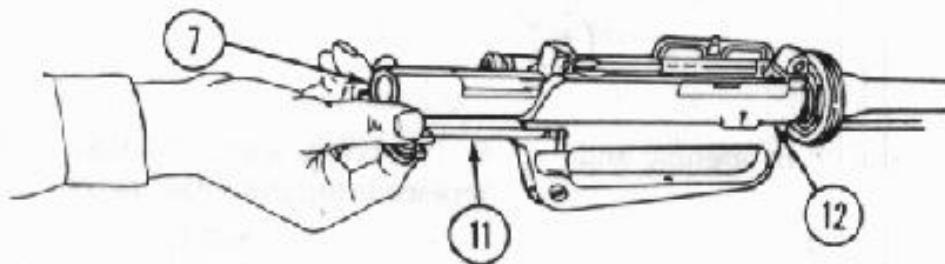

12. Push charging handle assembly (11) and bolt carrier assembly (7) together into upper receiver (12).

JOINING UPPER AND LOWER RECEIVERS

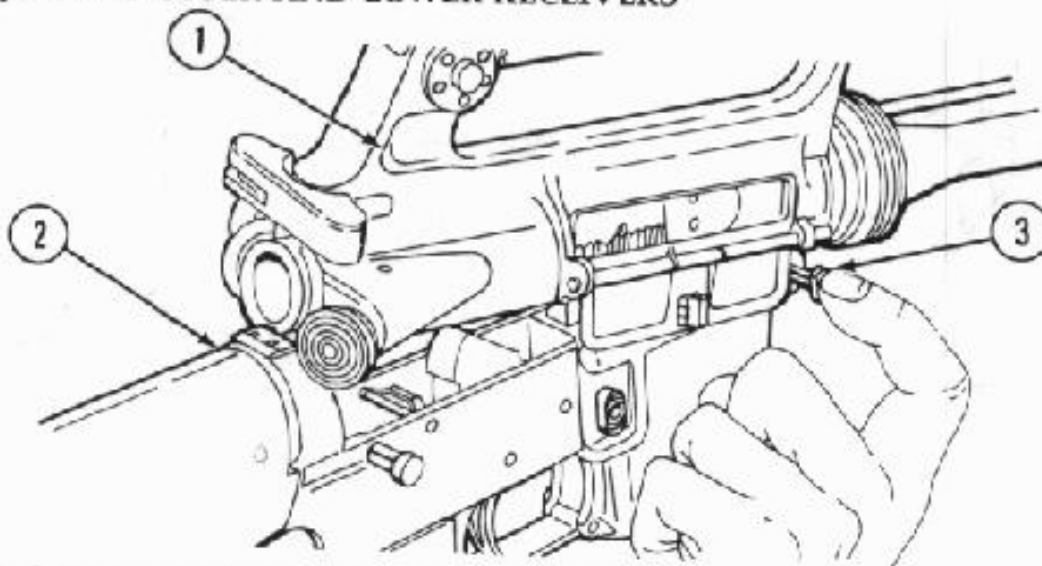

1. Join upper receiver (1) and lower receiver (2).
2. Align the pivot pin holes and push pivot pin (3) in.

CAUTION

Selector lever must be on SAFE before closing upper receiver.

3. Place selector lever (4) on SAFE before closing upper receiver

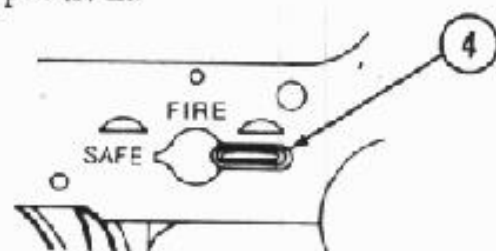

REASSEMBLY (Cont.)

Joining Upper and Lower Receivers

CAUTION

Ejection port cover must be closed before closing upper and lower receiver to prevent damage to cover.

4. Close ejection port cover (5).
5. Close upper receiver (1) and lower receiver (2). Push in takedown pin (6).

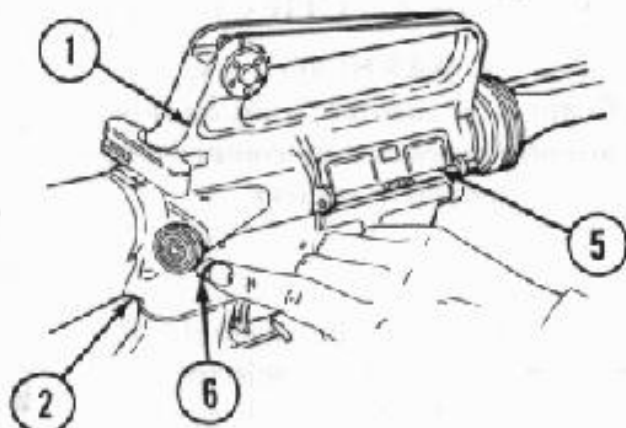

HAND GUARDS - THE "BUDDY SYSTEM"

1. Place the weapon on the buttstock (1) with one hand gripping the stock and the other gripping the lower end of the barrel. Insert hand guard into hand guard cap (2).
2. Have your buddy press down on slip ring (3).
3. Install hand guard (4).
4. Repeat these steps to install other hand guard.

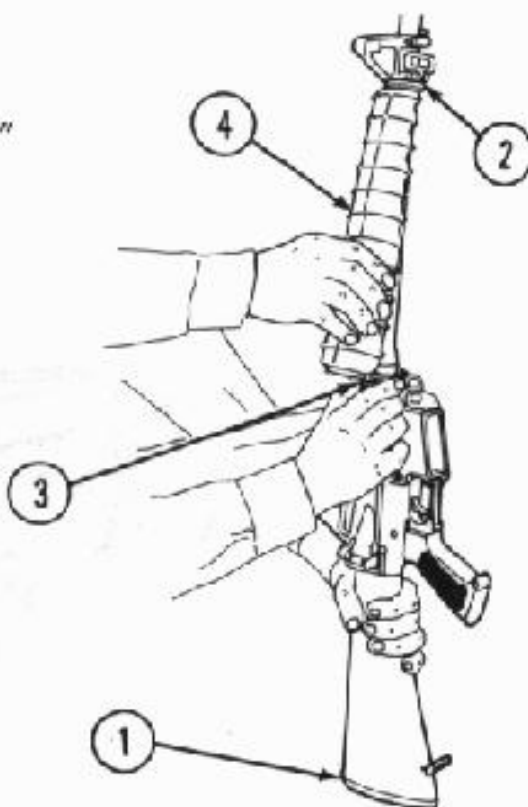

SLING

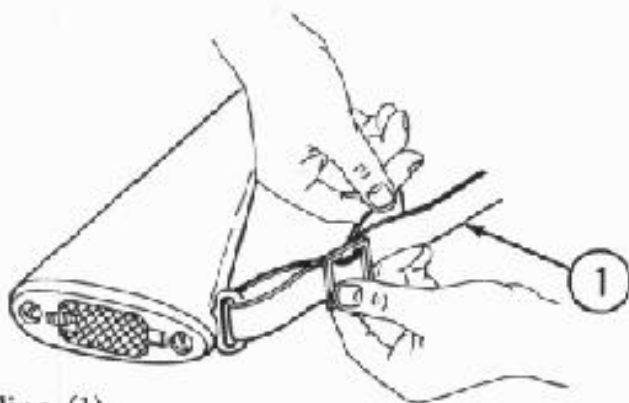

Attach sling (1).

FUNCTIONAL CHECK

WARNING

To avoid accidental firing, be sure cartridge magazine is removed and chamber is clear.

1. Pull charging handle assembly (1) to rear and release. Place selector lever (2) on SAFE. Squeeze trigger (3). Hammer should not fall.

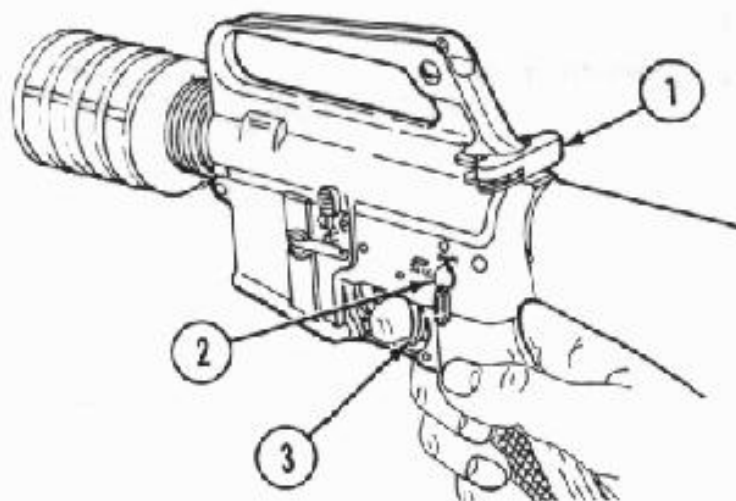
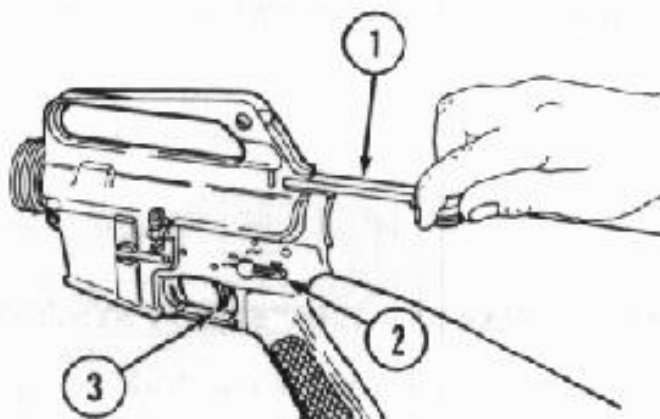

2. Place selector lever (2) on FIRE. Squeeze trigger (3); hammer should fall. Hold trigger to the rear. Pull charging handle assembly (1) to rear and release. Release trigger (3). You should hear a click as you release the trigger. Squeeze again; hammer should fall.